



Date: 11/22/09

Supersedes: 7/18/06

TECHNICAL DATA SHEET

VOONER VANEGARD® LIQUID RING VACUUM PUMP

Specified, constructed, tested, and guaranteed by:

Vooner FloGard® Corporation

P.O. Box 240360, Charlotte, NC 28224-0360
4729 Stockholm Court, Charlotte, NC 28273

Telephone: (704) 552-9314
Toll Free: 1-800-345-7879
Telefax: (704) 554-8230

Model: VG10 (DIN)

Type: Single stage rotor, cone shape ports, liquid ring vacuum pump

Sealing liquid flow rate nominal: 15”HgV (-L cone) - 75 lpm
20”-24”HgV (-M cone) - 75 lpm
24”-26”HgV (-H cone) - 130 lpm

Sealing liquid connection: 1” NPT

Shaft sealing: Packing

Bearing design: Double row spherical roller bearing, external, grease lubricated, Type: NSK 22315EAE4

Shaft diameter, drive end: 69.9 mm

Pump flange connections: 125 mm inlet, 100 mm outlet

Manifold flange connections: 200 mm inlet, 150 mm outlet

Approximate pump weight: 670 kg

MATERIAL CONSTRUCTION FEATURES

Model	Rotor	Cones	Heads	Bearing Carrier	Housing	Shaft	Packing Gland, Studs, Nuts
A	Ductile Iron	Cast Iron	Cast Iron	Carbon Steel	Cast Iron	Carbon Steel	316 SS
C	304 SS	304 SS	Cast Iron	Carbon Steel	Cast Iron	410 HT SS	316 SS
XVS	304 SS	304 SS	*316 SS	Carbon Steel	304 SS	410 HT SS	316 SS
SS4	304 SS	304 SS	304 SS	Carbon Steel	304 SS	316 SS	316 SS
SS6	316 SS	316 SS	316 SS	Carbon Steel	316 SS	316 SS	316 SS

(SS - cast stainless steel)

(HT - heat treated)

(N/A - not available)

(*Replaceable 316 SS Wear Plates on cast iron heads)

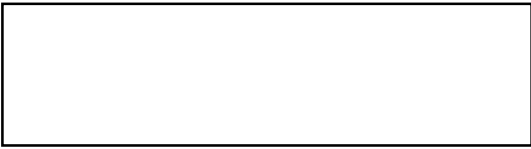

Vooner®

VACUUM PUMP, CONE PORT, SINGLE STAGE, LIQUID RING

MODEL: VG10-L

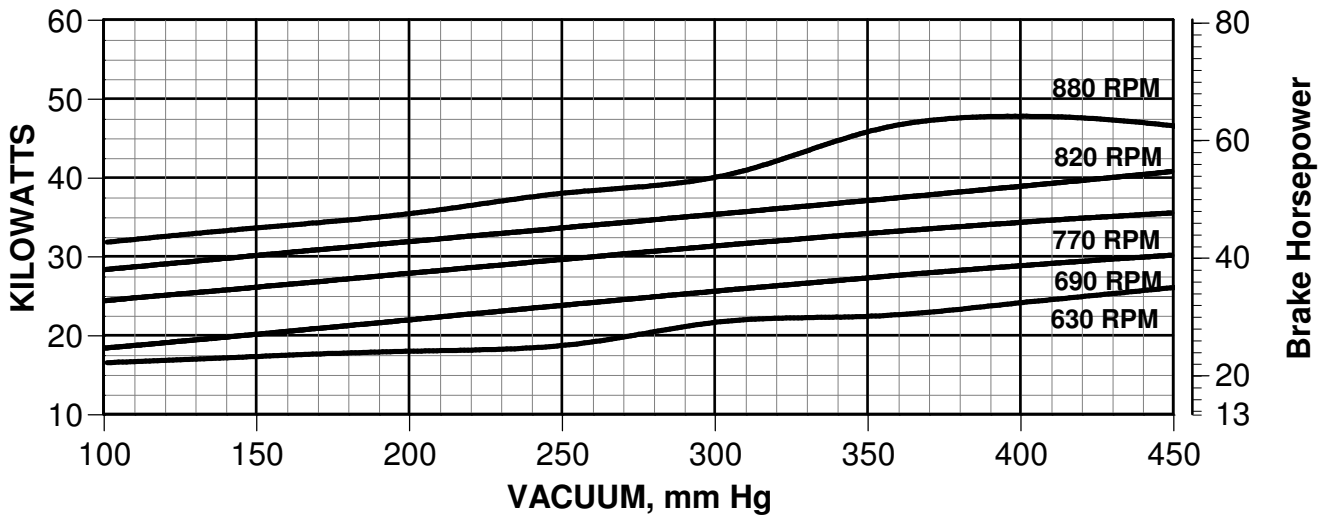
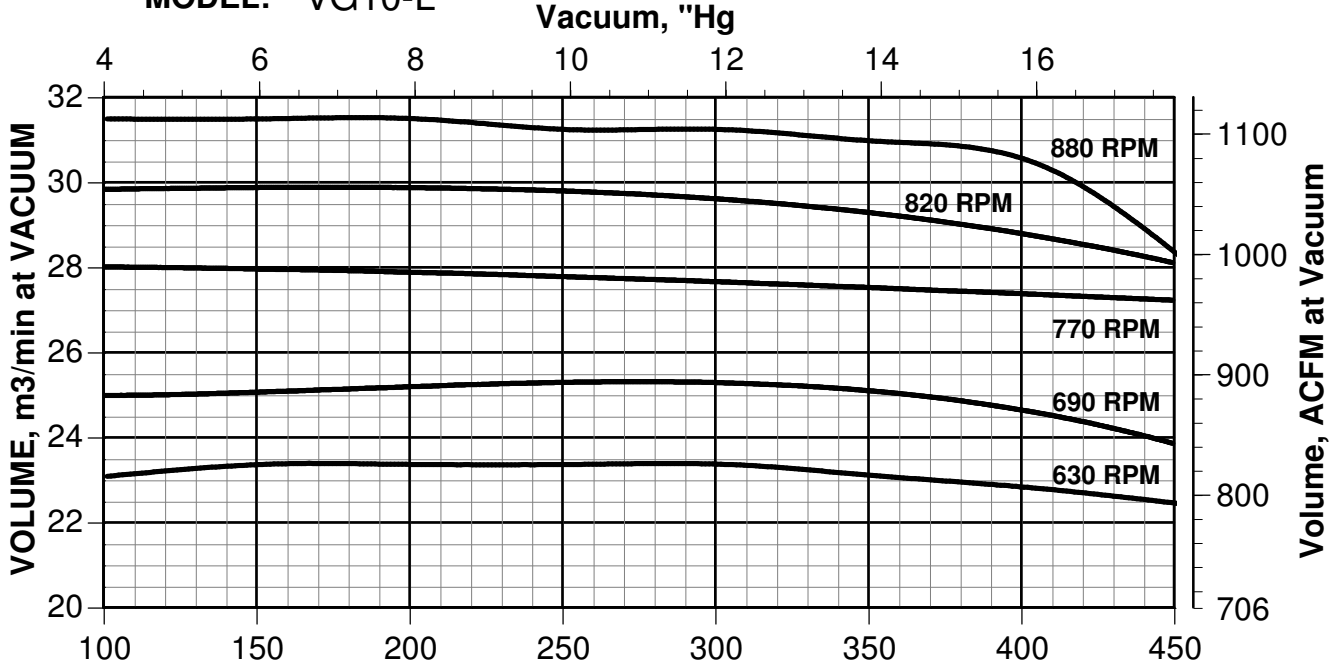

TEST DATA CONDITIONS:

INLET GAS TEMPERATURE: 15.6 C (60 F) @ 50% RELATIVE HUMIDITY
 BAROMETRIC PRESSURE: 760mm (29.92") Hg ABSOLUTE
 SEALING LIQUID TEMPERATURE: 15.6 C (60 F)

Issue date: 11/22/06
 Supersedes date: 01/20/01

Performance to Heat Exchange Institute Standards (HEI)

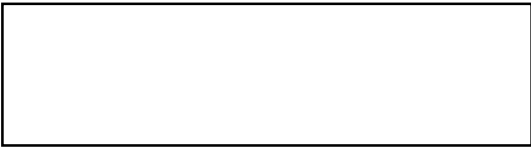

Vooner[®]

VACUUM PUMP, CONE PORT, SINGLE STAGE, LIQUID RING

MODEL: VG10-M

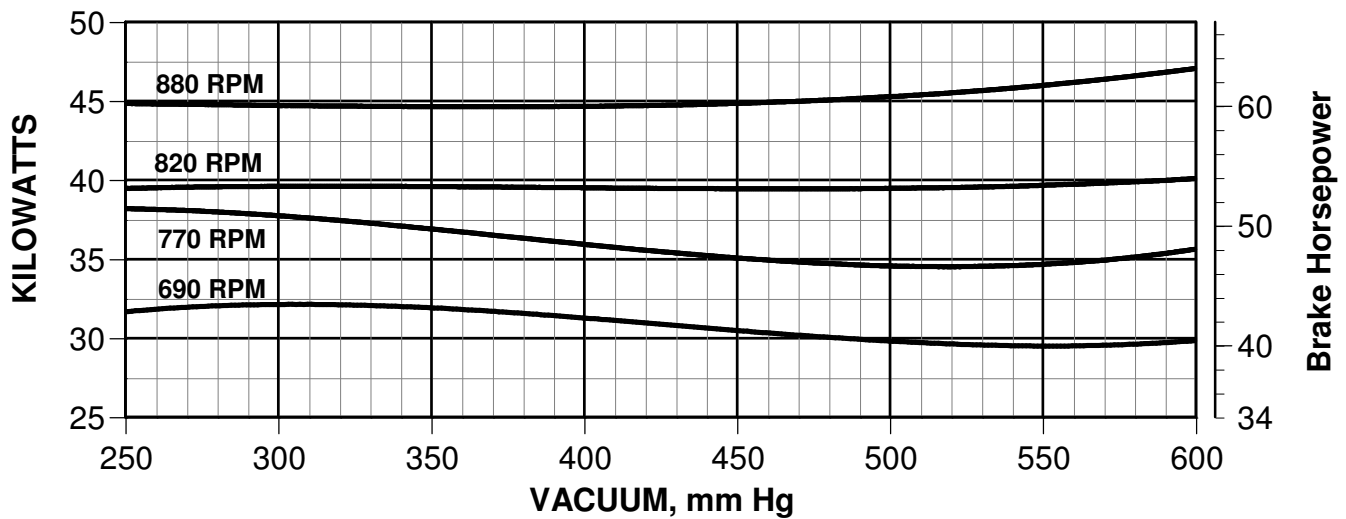
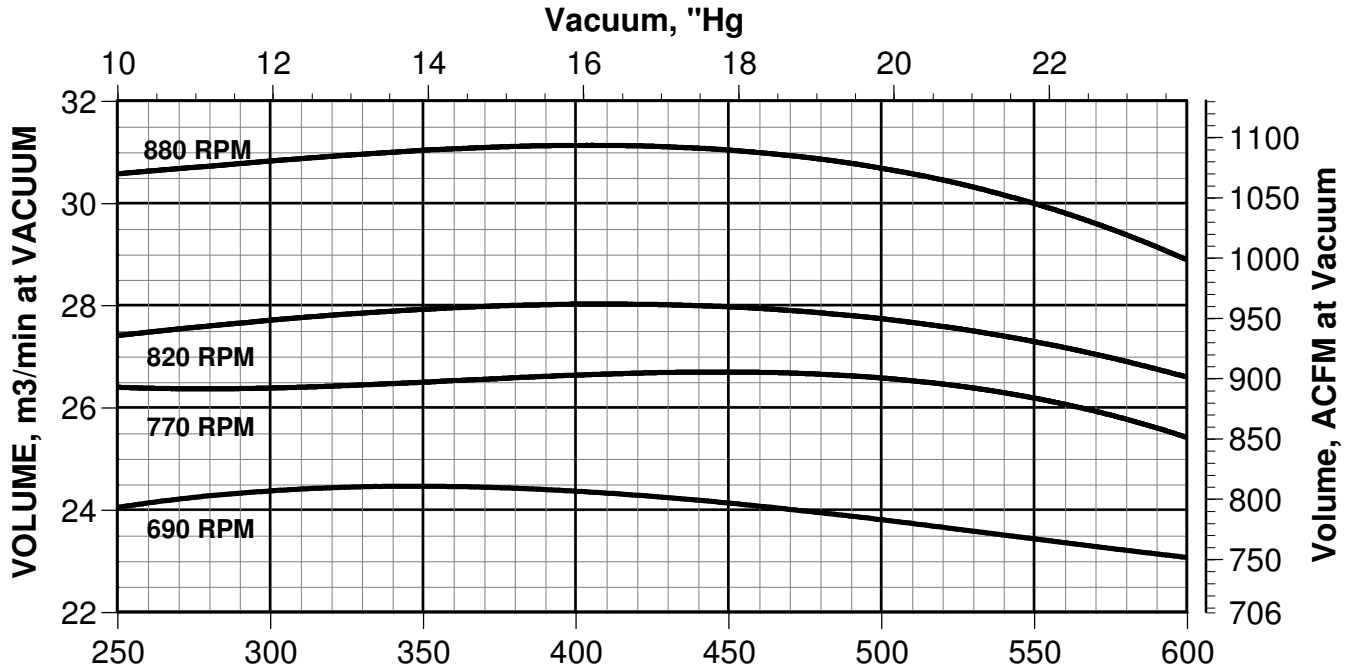

TEST DATA CONDITIONS:

INLET GAS TEMPERATURE: 15.6 C (60 F) @ 50% RELATIVE HUMIDITY

BAROMETRIC PRESSURE: 760mm (29.92") Hg ABSOLUTE

SEALING LIQUID TEMPERATURE: 15.6 C (60 F)

Issue date: 11/22/06

Supersedes date: 01/20/01

Performance to Heat Exchange Institute Standards (HEI)

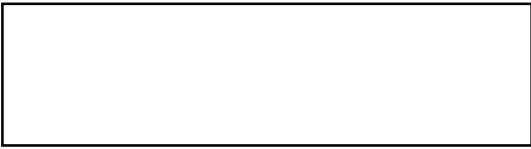

Vooner[®]

VACUUM PUMP, CONE PORT, SINGLE STAGE, LIQUID RING

MODEL: VG10-H

Vacuum, "Hg

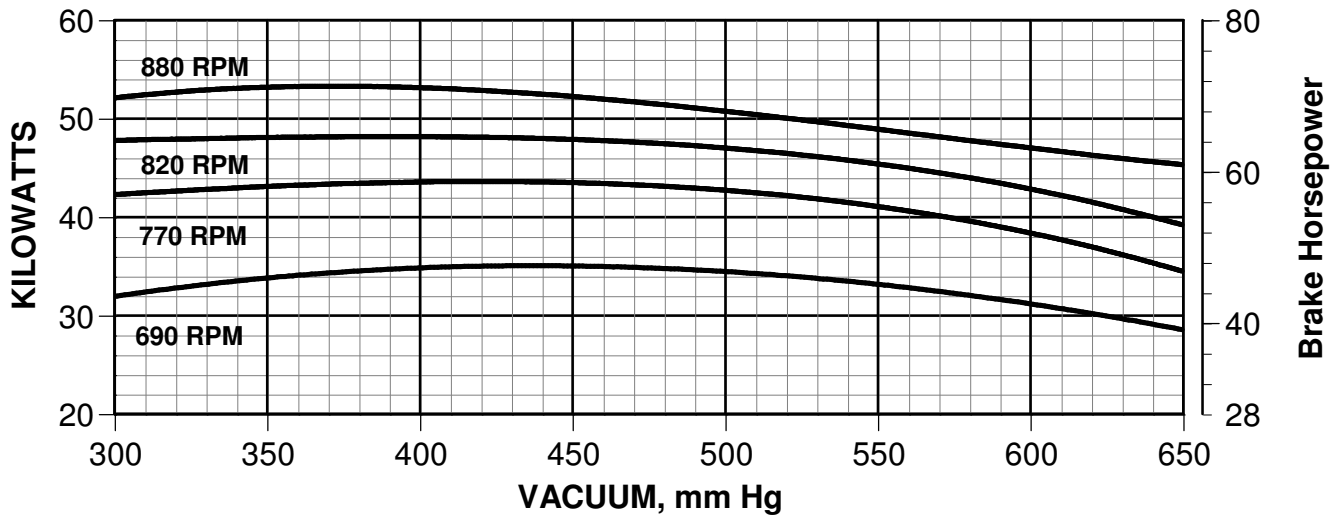
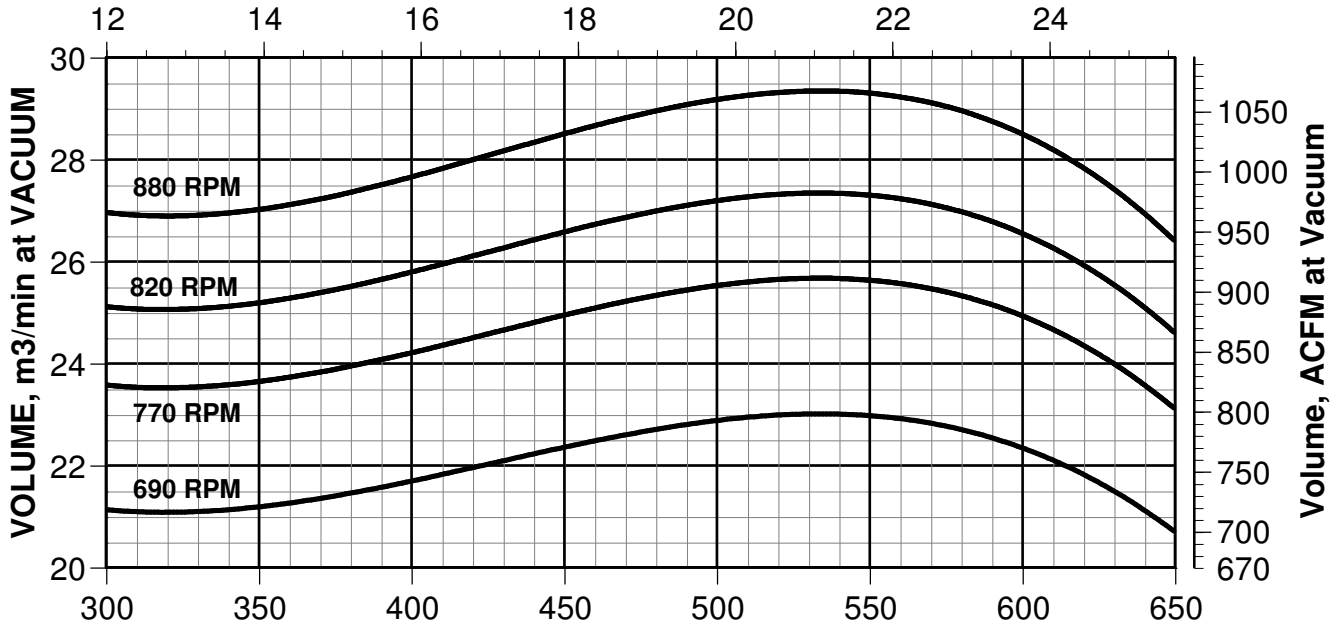

TEST DATA CONDITIONS:

INLET GAS TEMPERATURE: 15.6 C (60 F) @ 50% RELATIVE HUMIDITY

BAROMETRIC PRESSURE: 760mm (29.92") Hg ABSOLUTE

SEALING LIQUID TEMPERATURE: 15.6 C (60 F)

Issue date: 11/22/06

Supersedes date: 01/20/01

Performance to Heat Exchange Institute Standards (HEI)

Vooner[®], VaneGard[®] and FloGard[®] are registered trademarks of Vooner FloGard Corporation.
Copyright 2007, Vooner FloGard Corporation.

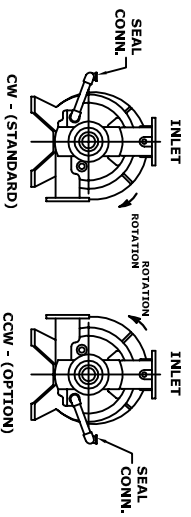
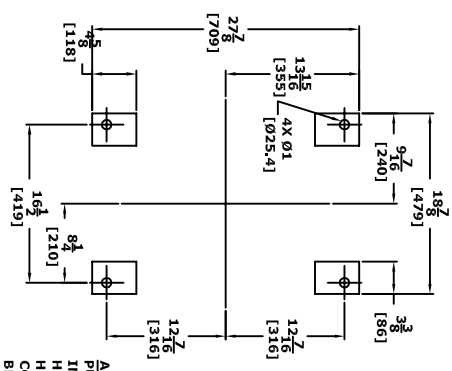
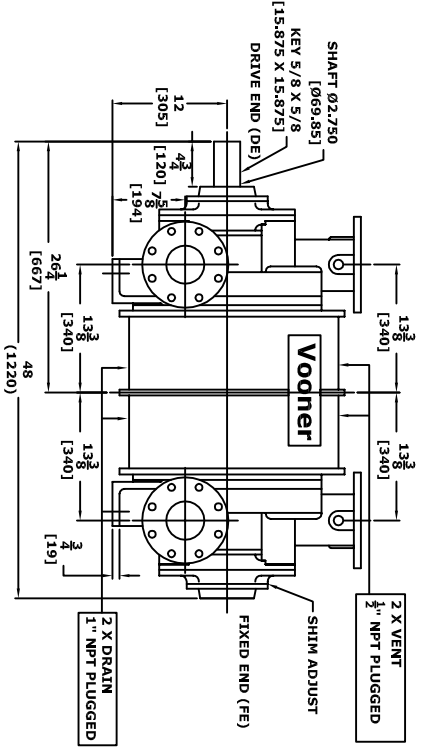
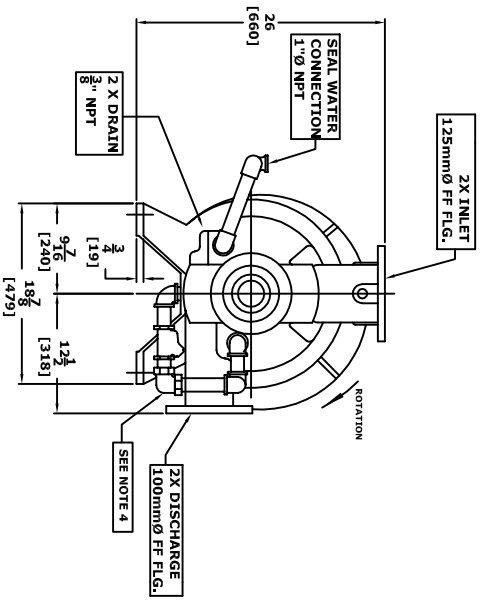

ASSY POSITIONS
(FACING DRIVE END)

- GENERAL NOTES:**
- 1) PRIMARY DIMENSIONS ARE IN INCHES. [mm]
 - 2) FINISHES TO DIM F10
 - 3) BOLT PATTERNS AND PATTERN THICKNESS. BOLT
 - 4) BOLT PATTERNS AND PATTERN THICKNESS
 - 5) ROPE STRONG CONNECTIONS ARE NET B2.1.
 - 6) SHROUD VENT RIDING FURNISHED ONLY ON "M" AND "H" MODELS.

APPROX. WEIGHTS

	LBS. [kg]
PUMP ASSY - DRY	1475 [669]
IMPELLER/SHAFT ASSY	428 [194]
HOUSING*	309 [140]
HEADS (EA.)*	265 [120]
CONES (EA.)*	35 [16]
BEARING CARRIER (EA)	35 [16]

PUMP FOOTING

* COMPONENTS ARE IRON. FOR S/STL ADD 13%.

THIS DOCUMENT CONTAINS PROPRIETARY INFORMATION OF YOONER FLOGARD CORPORATION, CHARLOTTE, NC, 28273 U.S.A. WRITTEN PERMISSION MUST BE OBTAINED FROM YOONER FLOGARD CORPORATION TO DISCLOSE TO OTHERS ANY INFORMATION CONTAINED HEREON. THIS DOCUMENT, AND COPIES THEREOF, ARE SUBJECT TO IMMEDIATE RETURN TO YOONER FLOGARD CORPORATION ON REQUEST.

<p>Vooner Flogard VOONER FLOGARD CORPORATION CHARLOTTE, NC 28273</p>			
SIZE	FSCM NO.	DWG NO.	REV
A	NONE	VG10 DIN	A
Scale: none		9/24/07	Sheet 1 of 1