



Date: 2/11/08

Supersedes: 7/18/06

**TECHNICAL DATA SHEET**

**VOONER FLOGARD® LIQUID RING VACUUM PUMP**

Specified, constructed, tested, and guaranteed by:

**Vooner FloGard® Corporation**

P.O. Box 240360, Charlotte, NC 28224-0360  
4729 Stockholm Court, Charlotte, NC 28273

Telephone: (704) 552-9314  
Toll Free: 1-800-345-7879  
Telefax: (704) 554-8230

**Model: V4L50 (DIN)**

Type: Single stage rotor, cone shape ports, liquid ring vacuum pump

Sealing liquid flow rate nominal: 15”HgV (-L cone) - 95-115 lpm  
20”-24”HgV (-M cone) - 150-190 lpm  
24”-28”HgV (-H cone) - 225-300 lpm

Sealing liquid connection: 1 1/2” NPT

Shaft sealing: Packing

Shaft diameter, drive end: 127.0 mm

Pump flange connections: 250 mm inlet (2), 200 mm outlet (2)

Approximate pump weight: 3402 kg

**MATERIAL CONSTRUCTION FEATURES**

Model	Rotor	Cones	Heads	Bearing Carrier	Housing	Shaft	Pkg Gland, Studs, Nuts
A	Ductile Iron	Cast Iron	Cast Iron	Carbon Steel	Cast Iron	Carbon Steel	316 SS
C	304 SS	304 SS	Cast Iron	Carbon Steel	Cast Iron	410 HT SS	316 SS
XVE4	304 SS	304 SS	*316 SS	Carbon Steel	**304L SS	410 HT SS	316 SS
XVE6	316 SS	316 SS	*316 SS	Carbon Steel	**316L SS	410 HT SS	316 SS
XVS	304 SS	304 SS	*316 SS	Carbon Steel	304 SS	410 HT SS	316 SS
SS4	304 SS	304 SS	304 SS	Carbon Steel	304 SS	316 SS	316 SS
SS6	316 SS	316 SS	316 SS	Carbon Steel	316 SS	316 SS	316 SS

(SS - cast stainless steel) (HT - heat treated)  
(\*Stainless Steel liner in cast iron housing)

(\*Replaceable 316 SS Wear Plates on cast iron heads)



# Vooner<sup>®</sup>

VACUUM PUMP, CONE PORT, SINGLE STAGE, LIQUID RING

MODEL: V4L50-L

Vacuum, "Hg

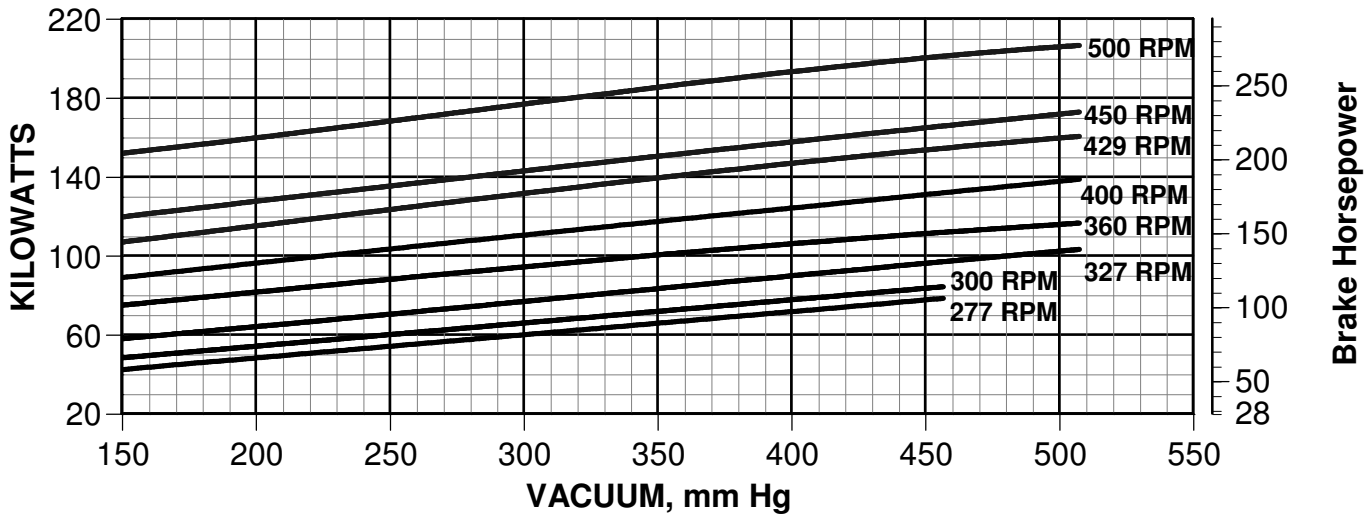
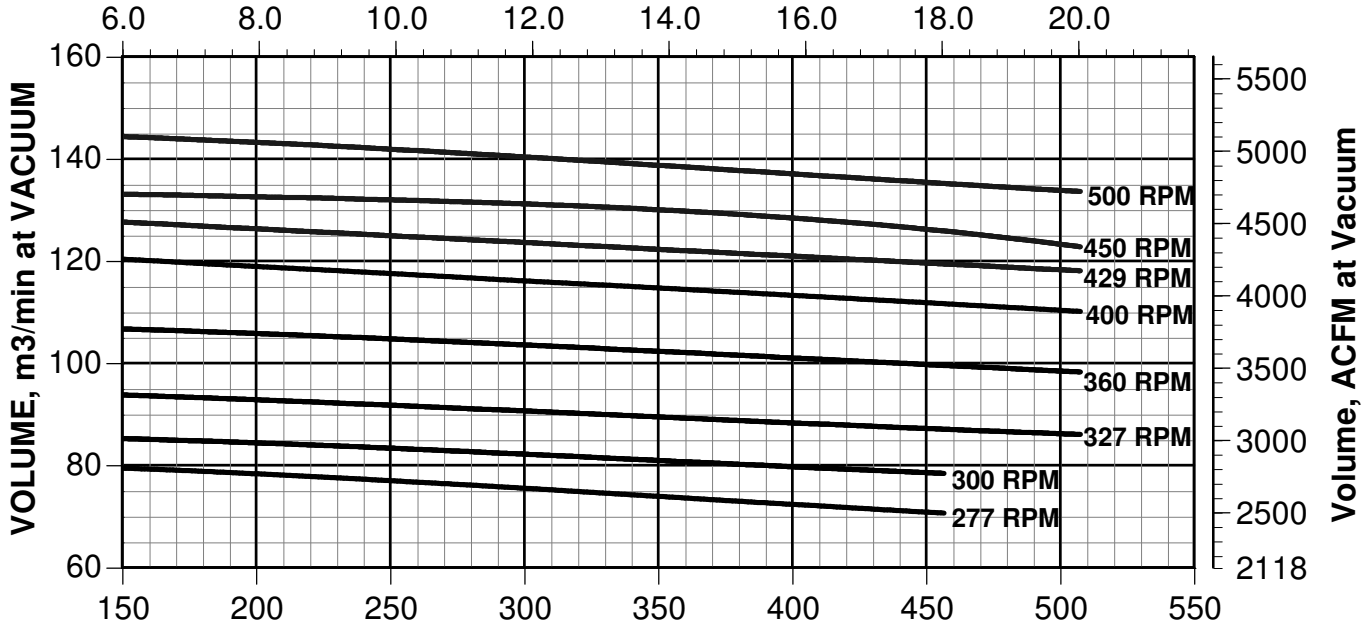

TEST DATA CONDITIONS:

INLET GAS TEMPERATURE: 15.6 C (60 F) @ 50% RELATIVE HUMIDITY

BAROMETRIC PRESSURE: 760mm (29.92") Hg ABSOLUTE

SEALING LIQUID TEMPERATURE: 15.6 C (60 F)

Issue date: 11/22/06

Supersedes date: 01/20/01

Performance to Heat Exchange Institute Standards (HEI)



# Vooner<sup>®</sup>

VACUUM PUMP, CONE PORT, SINGLE STAGE, LIQUID RING

MODEL: V4L50-M

Vacuum, "Hg

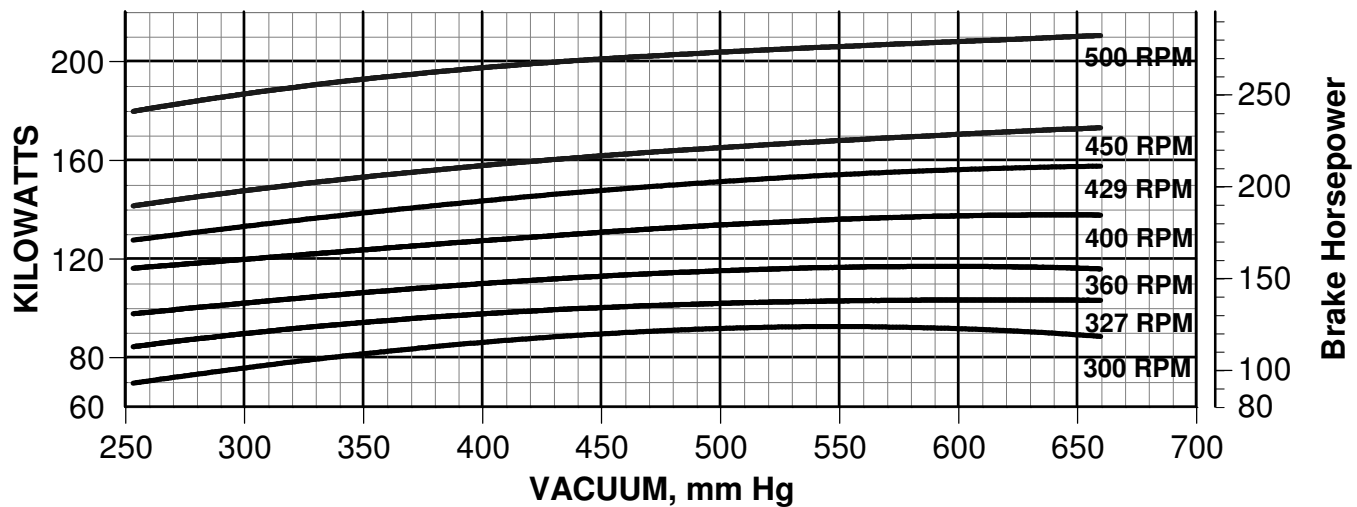
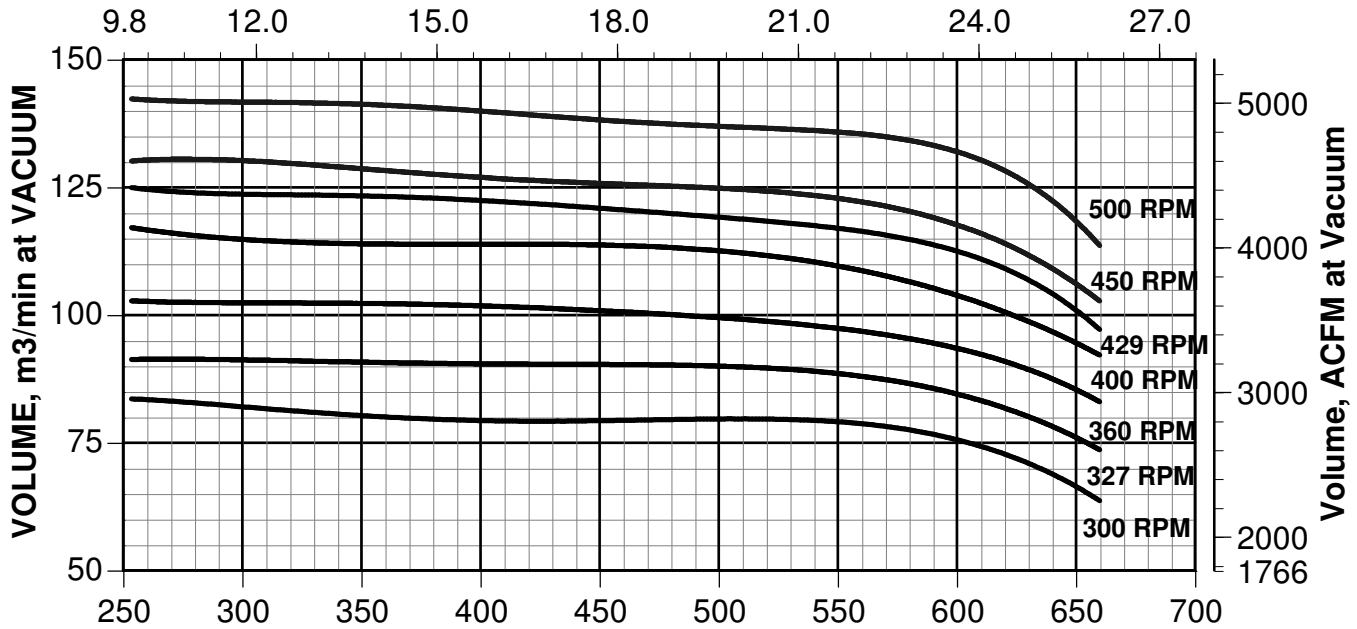

TEST DATA CONDITIONS:

INLET GAS TEMPERATURE: 15.6 C (60 F) @ 50% RELATIVE HUMIDITY

BAROMETRIC PRESSURE: 760mm (29.92") Hg ABSOLUTE

SEALING LIQUID TEMPERATURE: 15.6 C (60 F)

Issue date: 11/22/06

Supersedes date: 01/20/01

Performance to Heat Exchange Institute Standards (HEI)



# Vooner<sup>®</sup>

VACUUM PUMP, CONE PORT, SINGLE STAGE, LIQUID RING  
 MODEL: V4L50-H

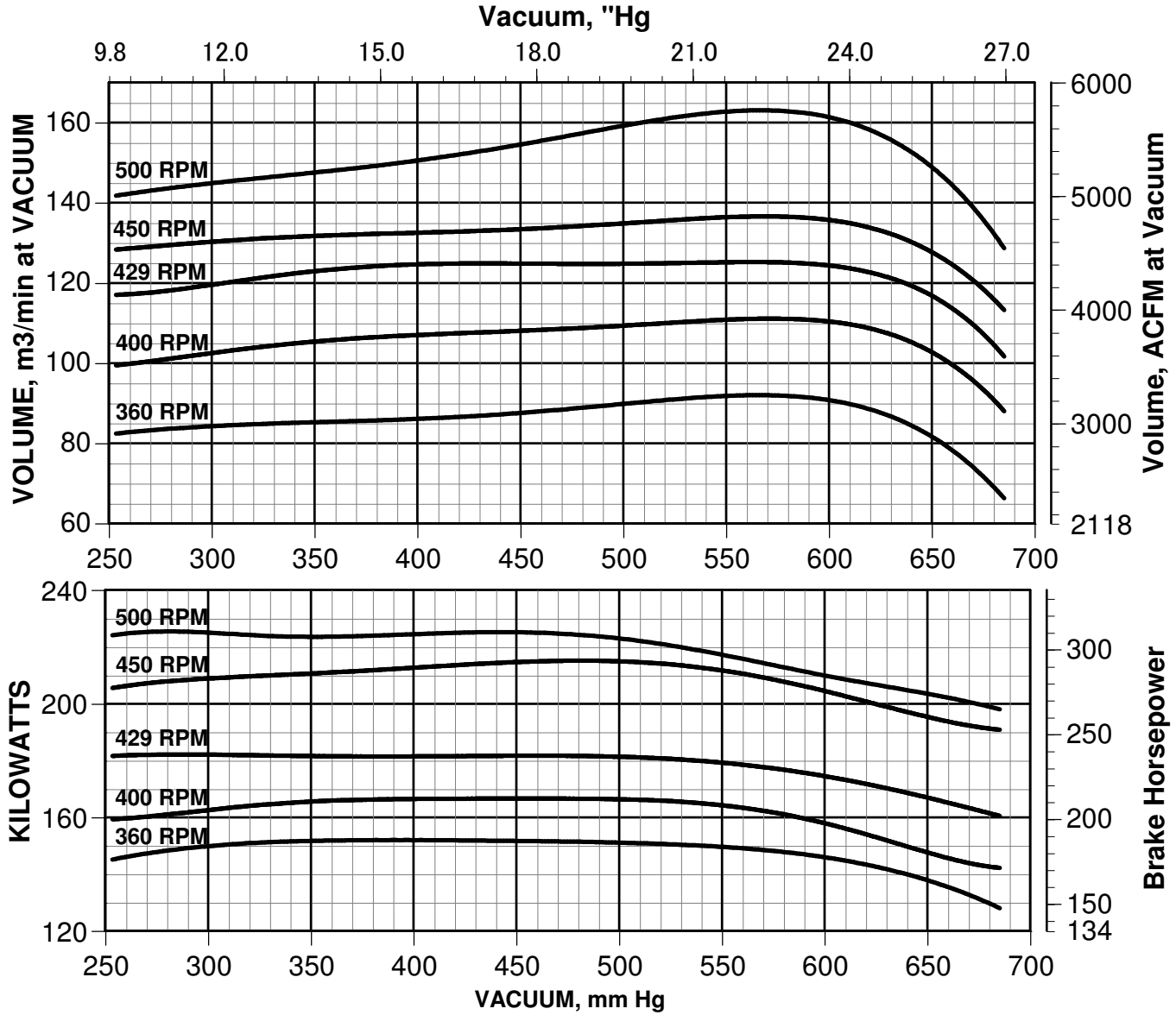

TEST DATA CONDITIONS:  
 INLET GAS TEMPERATURE: 15.6 C (60 F) @ 50% RELATIVE HUMIDITY  
 BAROMETRIC PRESSURE: 760mm (29.92") Hg ABSOLUTE  
 SEALING LIQUID TEMPERATURE: 15.6 C (60 F)

Issue date: 11/22/06  
 Supersedes date: 01/20/01

Performance to Heat Exchange Institute Standards (HEI)

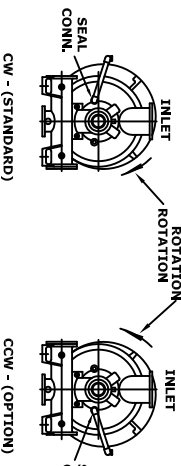
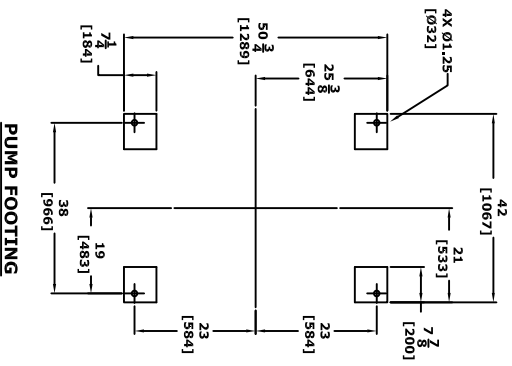
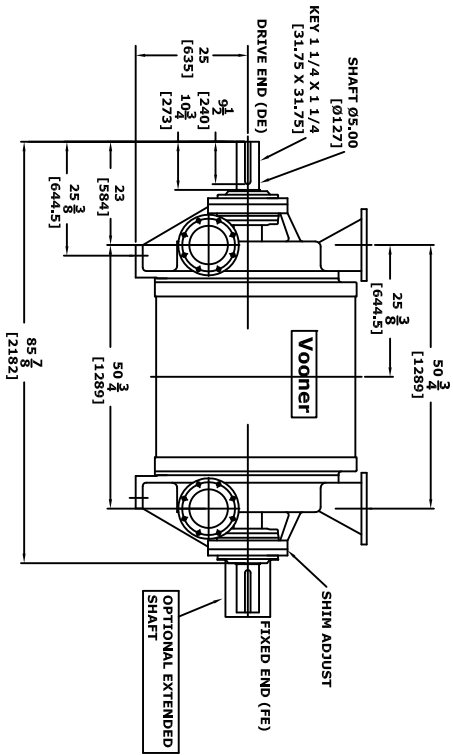
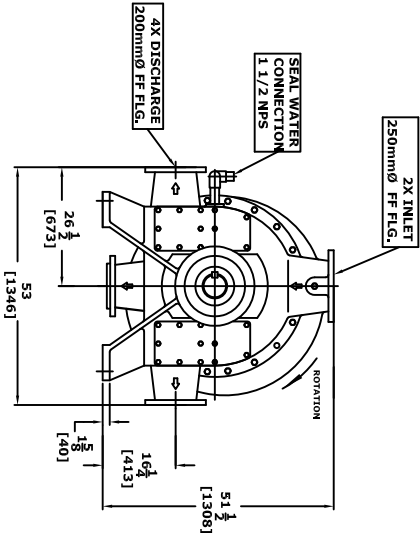

**ASSY POSITIONS**  
(FACING DRIVE END)

**APPROX. WEIGHTS**

PUMP ASSY - DRY	LBS. [KG]
IMPELLER/SHAFT ASSY	7500 [3400]
HOUSING*	2800 [1270]
HEADS/CONE ASSY (EA.)*	1460 [660]
	1560 [710]

\* COMPONENTS ARE IRON. FOR S/STL ADD 13%.

THIS DOCUMENT CONTAINS PROPRIETARY INFORMATION OF VOONER FLOGARD CORPORATION, CHARLOTTE, NC 28273 U.S.A. WRITTEN PERMISSION MUST BE OBTAINED FROM VOONER FLOGARD CORPORATION, TO DISCLOSE TO OTHERS ANY INFORMATION CONTAINED HEREON. THIS DOCUMENT, AND COPIES THEREOF, ARE SUBJECT TO IMMEDIATE RETURN TO VOONER FLOGARD CORPORATION ON REQUEST.

- GENERAL NOTES:**
- 1) PRIMARY DIMENSIONS ARE IN INCHES. [mm]
  - 2) FLANGES TO DIN P10 BOLT PATTERNS AND THICKNESS. BOLT HOLES STRADDLE CENTER LINES.
  - 3) PIPE THD. CONNECTIONS ARE ANSI B2.1.



**VOONER FLOGARD CORPORATION**  
CHARLOTTE, NC 28273

**OUTLINE DRAWING**  
V4L50 DIN

SIZE	FSCM NO.	DWG NO.	REV
A	NONE	V4L50 DIN	B

Scale: none      2/26/08      Sheet: 1 of 1