

 **Vooner
FloGard**[®]
vacuum pumps

VACUUM PUMP SYSTEM SPECIALIST SINCE 1984
Call: 1-800-345-7879 • Visit our website: www.vooner.com

VOONER FLOGARD® AND ITS INDUSTRIES



Vooner FloGard® manufactures and provides high-quality, conical ported, liquid ring vacuum pumps, replacement parts and services to a variety of industries. Customers rely on our products to keep their operations running efficiently while minimizing expensive downtime and protecting their bottom line.



POWER

Vooner FloGard provides a variety of pumps for the power generation industry. Long-lasting 316 stainless steel is used for fly ash bag filter recovery systems and condenser vacuum for geothermal power plants. Cast iron two-stage high vacuum pumps are used to exhaust condensers on steam turbines. Vooner pumps are also used for ethanol production, recirculation of natural gas of anaerobic digesters, and gypsum dewatering.



FOOD PROCESSING

Vooner FloGard stainless steel internal vacuum pumps are long-term and low-cost for chicken and fish evisceration, sugar manufacturing, and cornstarch drying.



MINING

Vacuum filtration of mineral slurries requires Vooner's rugged design, which includes cone ports and the liquid ring eccentric corner in a solid housing. Vooner offers different materials of construction using various amounts of stainless steel for erosion and corrosion protection.



PULP AND PAPER

Vooner FloGard supplies its vacuum pumps and accessories to the pulp and paper industry as a part of a paper process system through CVN Vooner Paper Machinery, Greeneville, TN. (423) 638-2211, info@cvnvooner.com, www.cvnvooner.com.

SINCE 1983,
VOONER FLOGARD HAS
BEEN ENGINEERING PUMPS
FOR LOWER LONG-TERM
COST THROUGHOUT
THE WORLD.



VISION STATEMENT

Command a prominent market position as innovator and supplier of the long-term lowest cost vacuum pumps. June 1995

OUR STRENGTHS

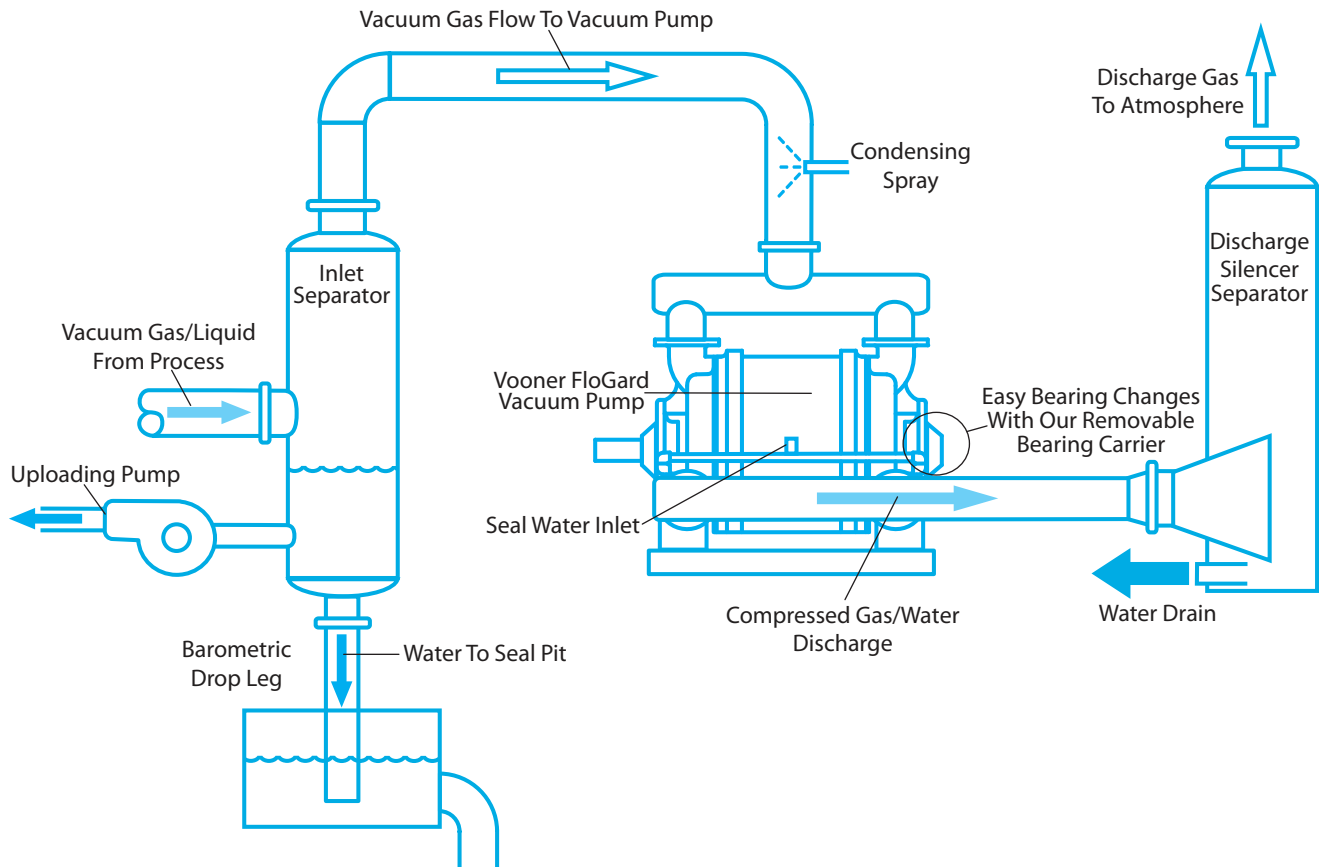

VACUUM PUMP BASE PLATE PACKAGE DESIGN

From our website, www.vooner.com, CAD drawings can be downloaded for user sizing and installation. Vooner also supplies baseplate package designs including pump, inlet and discharge manifolds, seal water system, condensing spray nozzle lines, inlet separators with unloading pump or barometric drop leg, discharge silencer separators, base, motors, sliding motor base, V-belt or direct coupling drive, and guard, all fully primed and painted and ready to drop in place.

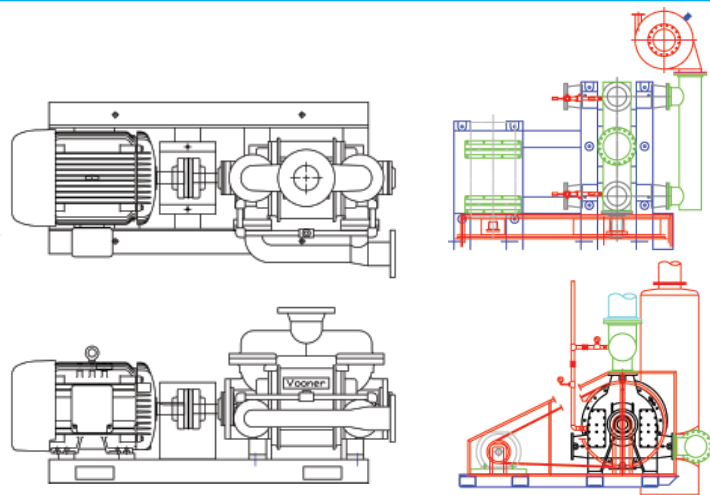

THE BENEFITS OF VOONER CONE PORT DESIGN

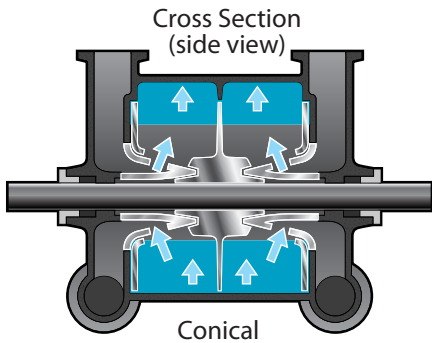

Conical



Vooner FloGard Cone Ports

VOONER FLOGARD CONE PORTS

Cone ports are the standard in the world market for vacuum service involving the passing of solids and having the ability to re-establish original clearances and therefore performance. Cone port openings are large enough to allow the passing of condensingspray on the inlet pipe and liquid and erosive solids from the process.

VOONER FLAT PLATE PORTS

Flat plate pumps are desired for clean gas without hazardous material carry over into the pump. They can easily achieve vacuum levels up to 28" Hg. Vacuum. Vooner is now able to offer bolt-in replacements of the 2BE1 large size flat plate pumps and several sizes of smaller flat plate pumps.

VOONER TWO-INLET PUMP DESIGN

All Vooner pumps are the world standard two inlet pumps. With this design, the average axial thrust loads on the bearings is zero. This is much less than a single-inlet, single-cone design which always has a thrust load in one direction. Vooner's two-inlet designs allow slower air velocity, less impact force inside the pump, and slower operating speed than single-inlet designs.

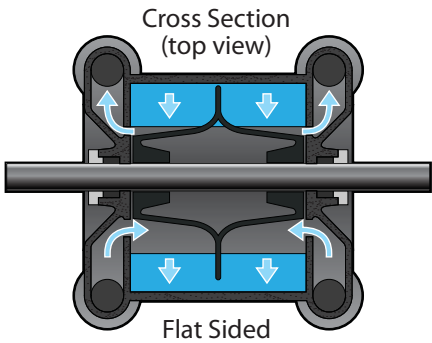

Flat Sided



Typical Flat Plate Ports

MAJOR BENEFITS

1. Passes slugs of process water small materials (large ports)
2. Can re-establish the clearances to regain original performance
3. Allows condensate in inlet pipe to pass through the pump

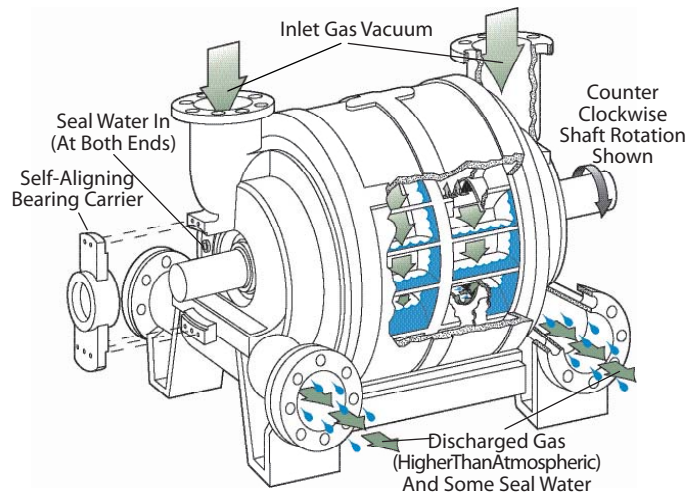

HOW THE PUMP WORKS

Liquid Ring Vacuum Pump

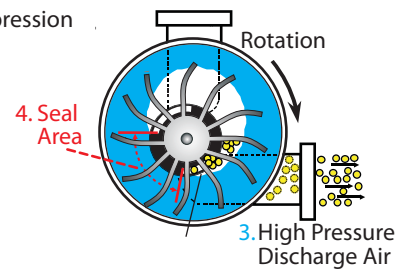
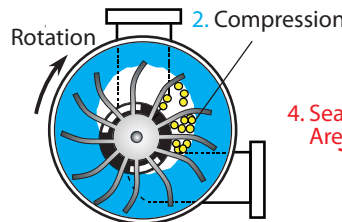
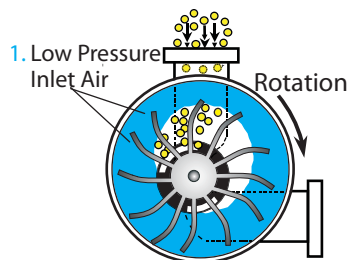
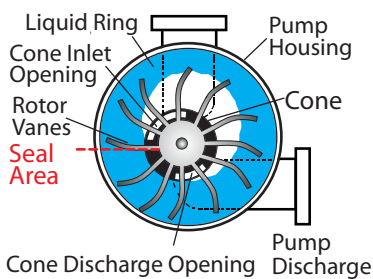

VALUE-ADDING BENEFITS FROM VOONER FLOGARD

CAST STAINLESS STEEL CONE AND ROTOR MINIMIZE VANESLIP

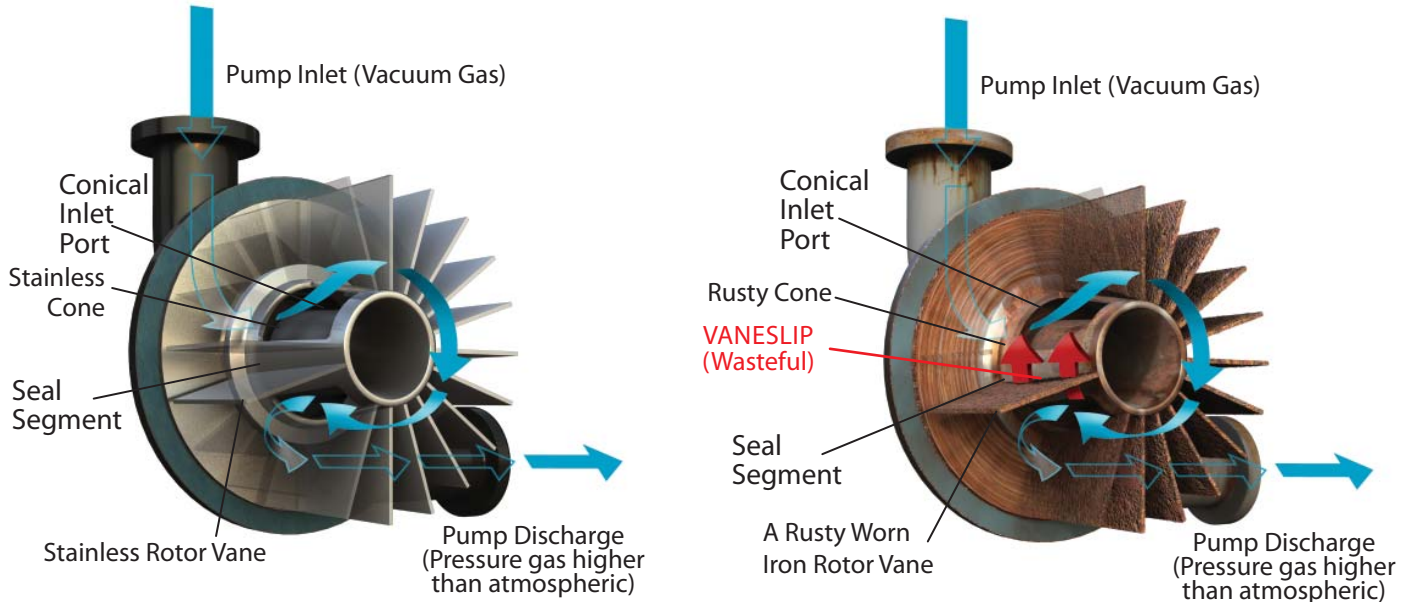

Vooner FloGard's Stainless Steel Difference For Better Airflow Performance

Stainless steel dynamically hardens its surface with the formation of chromic oxide. This resists erosive attack from solids and corrosive attack from chemicals. The standard materials for Vooner's rotors and cones are cast stainless steel. The very close tolerance clearance between the inside ends of the rotor blades and the cone surface of the seal segment can be maintained for long-term retention of performance.

Vooner FloGard's Stainless Steel Structural Difference

Stainless steel housings and heads can also be supplied for erosion and corrosion protection in very severe service such as mineral processing, power plant fly ash bag filter recovery systems, CO₂ gas compressors and geothermal condensers of turbines. Solid stainless steel is also specified for "non-sparking" applications with natural gas and anaerobic digester recirculation compressors.

EASY BEARING CHANGES

The unique, patented self-aligning Removable Bearing Carrier allows for bearing removal without removing the pump from the process piping and foundation. This feature will significantly reduce process downtime if a bearing change is required. Because pump disassembly is not required for a bearing change, the critical internal clearances are not changed.

Rusty. Worn. Vaneslip.

With cast iron pumps in operation, the iron oxide (rust) that forms on the rotor and cone surfaces is physically worn away with use, increasing the clearance between the rotor vanes and the seal segment of the cone. This decreases the seal which is to prevent the high pressure gas of the discharge segment from entering into the vacuum inlet segment of the pump.

The portion of the discharge gas that does not get discharged out of the pump, but leaks past the seal clearance between the vane of the rotor and seal segment of the cone it is called VANESLIP. VANESLIP allows high-pressure gas to enter the inlet segment and therefore robs space for new inlet air to enter the pump, thereby reducing the flow of vacuum gas being removed from the process.



VOONER FLOGARD®

PUMP AIRFLOW PERFORMANCE, ACFM (M³/MIN)

Dry Air Capacity at 60°F with 60°F seal water

| Single Stage Cone Port Model | Best efficiency, Slowest speed | | Lowest initial investment, Fastest speed | |
|------------------------------|--|---|--|--|
| | 19 - 21" Hg. Vacuum, (475-525 mm Hg. Vac.) L or M cone port | 26" Hg. Vacuum, (650 mm Hg. Vac.) M or H cone port | 19 - 21" Hg. Vacuum, (475-525 mm Hg. Vac.) L or M cone port | 26" Hg. Vacuum, (50 mm Hg. Vac.) M or H cone port |
| V4T130 | 7,600 (215) | 8,500 (241) | 12,400 (351) | 10,600 (300) |
| V4S110 | 6,800 (193) | 7,400 (210) | 11,000 (310) | 9,500 (280) |
| V4R95 | 5,500 (156) | 5,400 (160) | 8,800 (260) | 8,000 (230) |
| V4P75 | 4,600 (130) | 4,600 (130) | 7,500 (220) | 6,500 (190) |
| V4M55 | 3,500 (99) | 2,600 (80) | 5,700 (160) | 4,600 (130) |
| V4L50 | 2,800 (79) | 2,300 (65) | 4,800 (130) | 4,000 (110) |
| V490 | 7,400 (210) | 7,300 (210) | 9,700 (270) | 8,500 (240) |
| V460 | 5,200 (147) | 4,400 (130) | 6,800 (190) | 5,900 (170) |
| VG40 | 3,100 (88) | 2,500 (75) | 4,400 (120) | 4,000 (110) |
| VG30 | 2,300 (65) | 1,700 (50) | 3,000 (85) | 2,600 (75) |
| VG20 | 1,400 (40) | 1,000 (30) | 2,100 (60) | 1,400 (40) |
| VG10 | 800 (23) | 710 (20) | 1,100 (30) | 1,000 (28) |
| VG7 | 550 (16) | 450 (12) | 700 (20) | 600 (18) |
| VG4 | 350 (10) | 300 (8) | 450 (12) | 350 (10) |
| VG3 | 200 (6) | - | 300 (8) | - |

| Two Stage Cone Port Model | Best efficiency, Slowest speed | | Lowest initial investment, Fastest speed | |
|---------------------------|---|-----------------------------------|--|-----------------------------------|
| | 19 - 21" Hg. Vacuum, (475-525 mm Hg. Vac.) | 29" Hg. Vacuum, (735 mm Hg. Vac.) | 19 - 21" Hg. Vacuum, (475-525 mm Hg. Vac.) | 29" Hg. Vacuum, (735 mm Hg. Vac.) |
| VTS20 | 1,680 (48) | 1,100 (31) | 2,050 (58) | 1,200 (34) |
| VTS10 | Please call the Vooner Office: 1-800-345-7879 | | | |

| Single Stage Flat Port Model | Best efficiency, Slowest speed | | Lowest initial investment, Fastest speed | |
|------------------------------|--|-----------------------------------|--|----------------------------------|
| | 19 - 21" Hg. Vacuum, (475-525 mm Hg. Vac.) | 24" Hg. Vacuum, (600 mm Hg. Vac.) | 19 - 21" Hg. Vacuum, (475-525 mm Hg. Vac.) | 24" Hg. Vacuum, (50 mm Hg. Vac.) |
| FG147 | 10,000 (283) | 9,500 (268) | 14,600 (413) | 13,200 (373) |
| FG107 | 6,520 (184) | 6,050 (171) | 10,300 (291) | 9,250 (262) |
| FG77 | 4,350 (123) | 4,040 (114) | 7,370 (209) | 6,620 (187) |
| FG57 | 3,370 (95) | 3,140 (89) | 5,430 (154) | 4,820 (137) |
| FG100 | 485 (14) | 430 (12) | | |
| FG65 | 310 (8.8) | 290 (8.2) | | |

| Two Stage Flat Port Model | Best efficiency, Slowest speed | | Lowest initial investment, Fastest speed | |
|---------------------------|--|-----------------------------------|--|-----------------------------------|
| | 19 - 21" Hg. Vacuum, (475-525 mm Hg. Vac.) | 27" Hg. Vacuum, (675 mm Hg. Vac.) | 19 - 21" Hg. Vacuum, (475-525 mm Hg. Vac.) | 27" Hg. Vacuum, (675 mm Hg. Vac.) |
| FGT150 | 1,820 (52) | 2,070 (59) | 1,480 (42) | 1,870 (53) |
| FGT100 | 700 (20) | 810 (23) | 890 (25) | 980 (28) |
| FGT80 | 365 (9.2) | 360 (10) | 455 (13) | 505 (14) |
| FGT50 | 265 (7.5) | 290 (8.2) | | |
| FGT40 | 125 (3.5) | 128 (3.6) | | |
| FGT32 | 33 (0.9) | 32 (0.9) | | |

INTERCHANGEABLE MODEL CHART

| Single Stage Cone Port | | Small Flat Plate | |
|------------------------|----------|------------------|----------|
| Vooner | Nash | Vooner | Travaini |
| VG3 | CL-300 | FG65 | TRVA 65 |
| VG4 | CL-400 | FG100 | TRVA 100 |
| VG7 | CL-700 | FGT32 | - |
| VG10 | CL-1000 | FGT40 | TRHC 40 |
| VG20 | CL-2000 | FGT50 | TRHC 50 |
| VG30 | CL-3000 | FGT80 | TRHC 80 |
| VG40 | CL-4000 | FGT100 | TRHC 100 |
| V460 | CL-6000 | FGT150 | TRHC 150 |
| V490 | CL-9000 | Large Flat Plate | |
| V4L50 | 904-L | Vooner | Siemens |
| V4M55 | 904-M | FG57 | 2BE1405 |
| V4P75 | 904-P | FG77 | 2BE1505 |
| V4R95 | 904-R | FG107 | 2BE1605 |
| V4S110 | 904-S | FG147 | 2BE1705 |
| V4T130 | 904-T | | |
| Two Stage Cone Port | | | |
| Vooner | Nash | | |
| VTS10 | AT1004,6 | | |
| VTS20 | AT2004,6 | | |

STAINLESS STEEL - FOR LONGER LIFE

| Pump Component Metallurgy | | | | | | |
|---------------------------|--------|--------|-------------------|----------------------|--------|----------------|
| Material Code | Rotor | Cones | Housing | Heads | Shaft | Packing Glands |
| A | DI | CI | CI | CI | CS | 316 SS |
| C | 304 SS | 304 SS | CI | CI | 410 SS | 316 SS |
| S | 304 SS | 304 SS | 304 SS | CI | 410 SS | 316 SS |
| XV5 | 304 SS | 304 SS | 304 SS | CI+316 SS wearplates | 410 HT | 316 SS |
| XVE4 | 304 SS | 304 SS | CI+304L SS lining | CI+316 SS wearplates | 410 SS | 316 SS |
| XVE6 | 316 SS | 316 SS | CI+316L SS lining | CI+316 SS wearplates | 410 SS | 316 SS |
| SS4 | 304 SS | 304 SS | 304 SS | 304 SS | 316 SS | 316 SS |
| SS6 | 316 SS | 316 SS | 316 SS | 316 SS | 316 SS | 316 SS |

DI - Ductile Iron SS - Stainless Steel
CI - Cast Iron CS - Carbon Steel



Individual performance curves can be downloaded



Three Year Warranty on material and workmanship

NASH is a trademark of Gardner Denver, Inc.
Travaini is a registered mark of Pompetravaini SpA of Italy
Siemens is a trademark of Siemens AG of Germany

QUALITY CONTROL

- Test and procedures mutually developed and part of purchase contract
- Performance test based on Heat Exchange Institute (HEI) specification for testing vacuum pumps
- Witness of test is free and invited

TESTED AND GUARANTEED.

All Vooner pumps are performance tested in Charlotte, NC, U.S.A., according to HEI specifications prior to shipping to the customer. Our rigorous quality control inspections and performance tests guarantee that each Vooner pump matchesthecapacityandpowerconsumption shown on our performance curves.



A Vooner FloGard two inlet cone port pump tested in the Charlotte, NC, test facility



A Vooner FloGard high-vacuum two-stage pump being tested

ORIFICE PLATE TESTING

Measure of airflow at vacuum of installed pumps based on Heat Exchange Institute, HEI standards. Vooner FloGard testing and report writing service basis for operating costs for a number of years.

- Seal water, volume per year
- Electrical energy, kw per year
- Maintenance
- Rebuild

VACUUM PUMP, ACFM AT VACUUM LEVEL

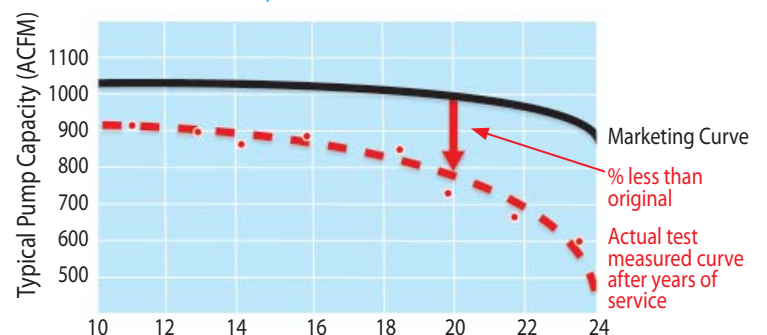



Vooner FloGard Corporation
P.O. Box 240360 • Charlotte, NC 28224-0360
4729 Stockholm Court • Charlotte, NC 28273
1-800-345-7879 • 704-552-9314 • Fax: 704-554-8230

www.vooner.com

Vooner FloGard Pumps are running today in ...



© VG, VOONER and FLOGARD are registered trademarks of Vooner FloGard Corporation
© 2008 VOONER FLOGARD CORPORATION

Vooner FloGard Represented By _____

